

**ROOF DETAILS**

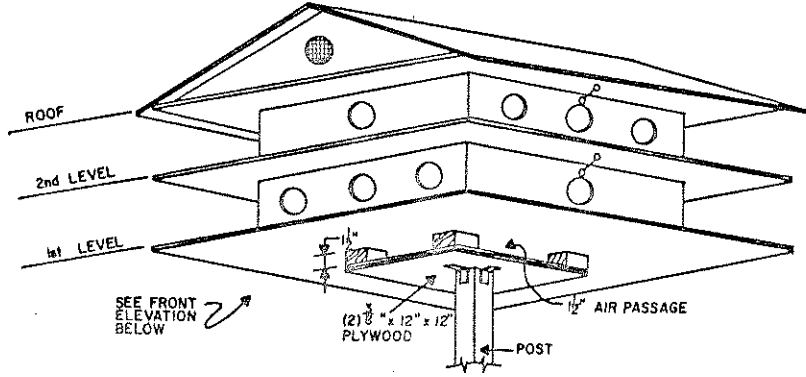

**VIEW OF TWO LEVEL BIRDHOUSE**

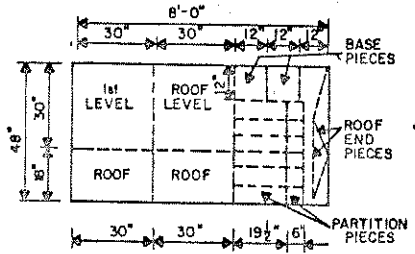
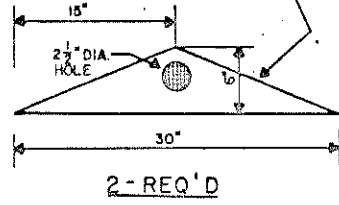

**PLYWOOD CUTTING DIAGRAM FOR ONE LEVEL BIRDHOUSE**

0" 4" 8" 12" 15"  
UNLESS OTHERWISE NOTED

NOTE: TO FASTEN PARTITIONS, SLOT PLYWOOD, GLUE, OR USE MOULDING

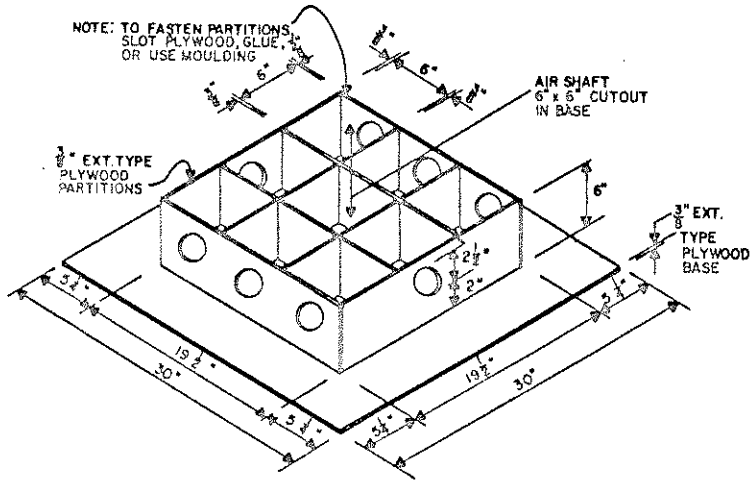

**DETAILS OF ONE LEVEL**

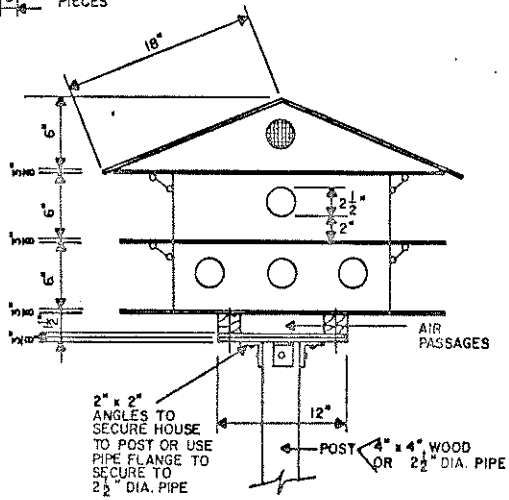

NOTE: 1. LOCATE NEAR AREA NEEDING INSECT CONTROL.  
2. HEIGHT ABOVE GROUND IS 15'-20'

**FRONT ELEVATION**

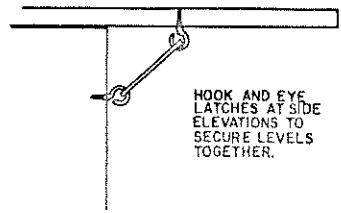

**DETAIL FOR LATCHES**

COOPERATIVE EXTENSION WORK IN  
AGRICULTURE AND HOME ECONOMICS

AND  
UNITED STATES DEPARTMENT OF AGRICULTURE COOPERATING

PURPLE MARTIN BIRDHOUSE

NJ '69    EX. 6344    SHEET 1 OF 1